

Performance characterization of advanced Electro-Optical and Infrared imaging systems

Piet Bijl
TNO

Delft, the Netherlands

21 June 2023

Organized by Penta projects:
2020005 Mantis Vision
2021004 Imagination

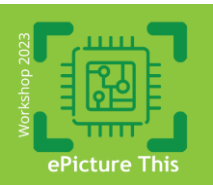

Workshop 2023

Outline

- History of modelling Target Acquisition performance
- TOD: Triangle Orientation Discrimination method
 - TOD test method
 - Analytical TOD model
 - DRI range model
 - Modelling the imaging chain
- Current operational models
- Calculation example

History

- Since Johnson in the 1950's, Target Acquisition (TA) performance prediction for imaging systems with the human-in-the-loop is dominated by the response on periodic test targets or edges
 - D: Detection (50%) = 1 lp on target ($N_{50} = 1$)
 - R: Recognition (50%) = 4 lp on target ($N_{50} = 4$)
 - I: Identification (50%) = 6.4 lp on target ($N_{50} = 6.4$)
- Many Target Acquisition models based on this principle
 - Measurement/prediction of the Minimum Resolvable Contrast (MRC) or Temperature Difference (MRTD)
 - Conversion of target size and range to number of cycles on target
 - Gives a probability of D, R and I as a function of range (including atmosphere)

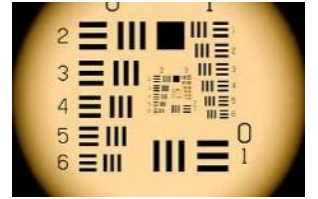

USAF 1951

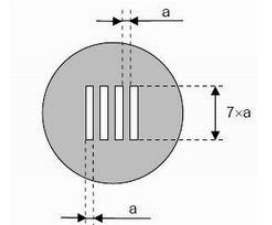

MRC/MRTD

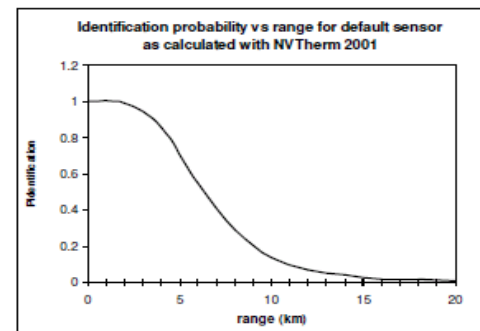

Rotakin

History

- The approach is nice and intuitive, but has a variety of drawbacks:
 - MRC for well-sampled systems too steep compared to threshold for real objects
 - ! When tuned to DRI range for high contrasts, it will be too optimistic for lower contrast targets
 - MRC is not well defined for under-sampled imaging systems
 - ! What to do above the Nyquist frequency: cut-off the MRC (and favor low sensitivity sensors systems)?
 - ! MRC cannot be measured for moving targets (so the effect of motion on performance is not included)
 - ! Advanced signal processing often uses motion (so advanced systems are excluded in favor of simple systems)
 - Thresholds are measured with a Yes/No task
 - ! This introduces observer bias between (and within) human observers
 - ! It is difficult to develop a simulation model of the human visual system performing this task

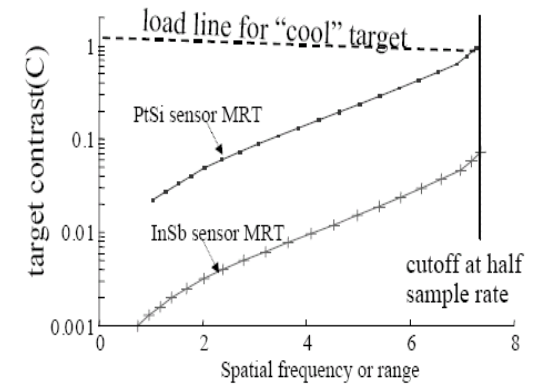
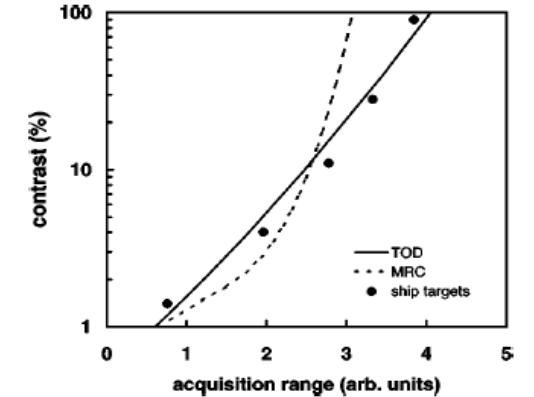
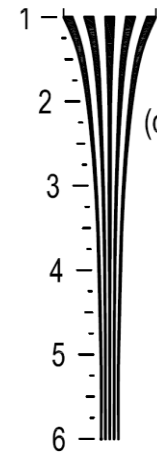
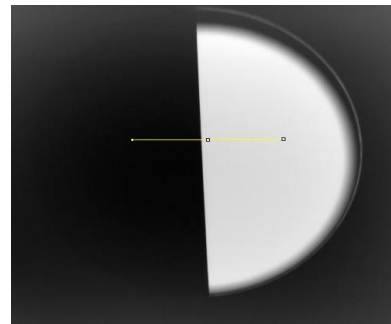

Figure 1. The Half-Sample Rate Limit of Performance.

History

- Some other standardized tests (e.g. edges and hyperbolic wedges, ISO 12233):
 - They are useful but characterize only part of the system response
 - Edge responses characterize the presample MTF of the system
 - Hyperbolic wedges measure the Nyquist (half the sampling) frequency of a system
 - They measure complementary system properties but are often considered as interchangeable
 - The human is hardly involved and they lack connection with human performance in operational conditions



TOD (TNO development)

- TOD = Triangle Orientation Discrimination method
 - Non-periodic triangle test pattern represents target features
 - 4-alternative forced-choice task (Up, Down, Left, Right) allows
 - bias-free observer responses and
 - easy definition of automatic classification task
- Characterizes imaging systems performance with the human-in-the-loop:
 - describes the ability to discriminate between ▲ ▼ ► ◀
 - describes the ability to discriminate between real objects under practical circumstances (Target Acquisition)
 - Validated for a wide variety of imaging systems and operational conditions
- Includes system test, analytical model, image-based model and DRI range model
 - Useful for procurement processes, acceptance testing, and system design

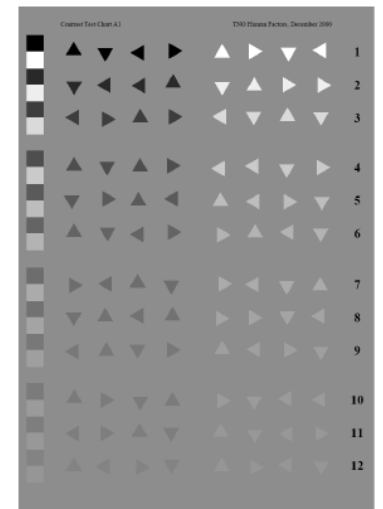
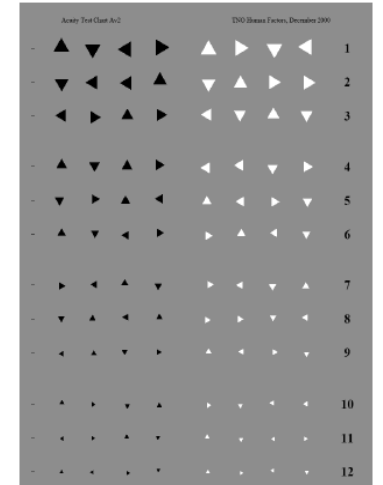

TOD Test method

- Simple spatial test pattern
 - Triangle Up, Down, Right, Left
- Simple observer task:
 - indicate triangle orientation
 - Bias-free
- Both contrast and size varied and presented several times
- Statistical analysis yields 75% correct contrast ($+ \sigma$) as function of size
- TOD curve: contrast threshold plotted against reciprocal angular size
- DRI ranges are directly related

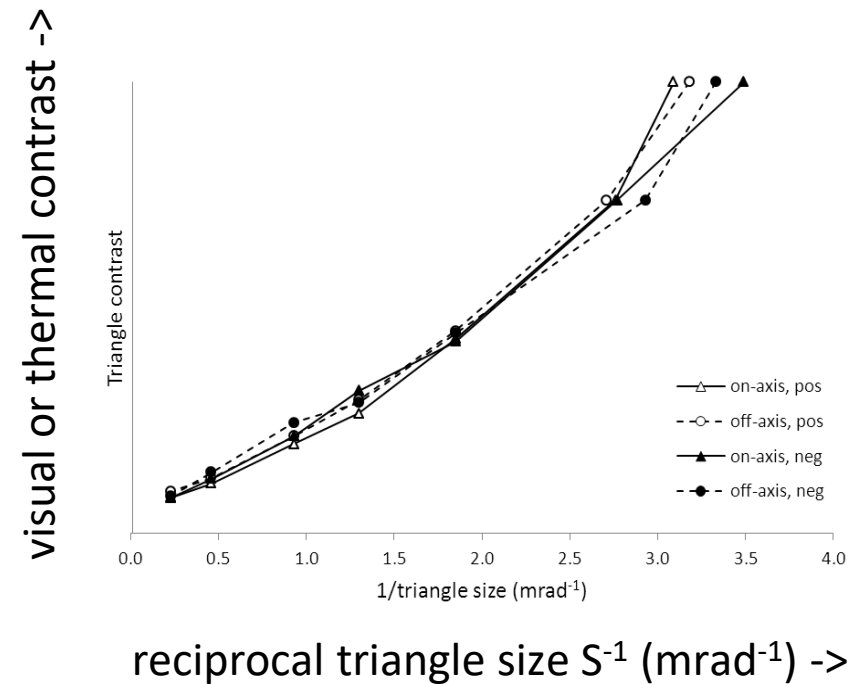
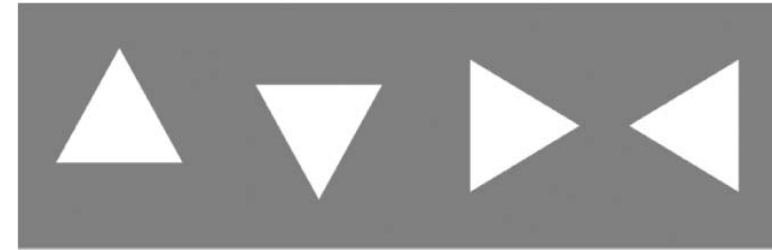

Test method and equipment

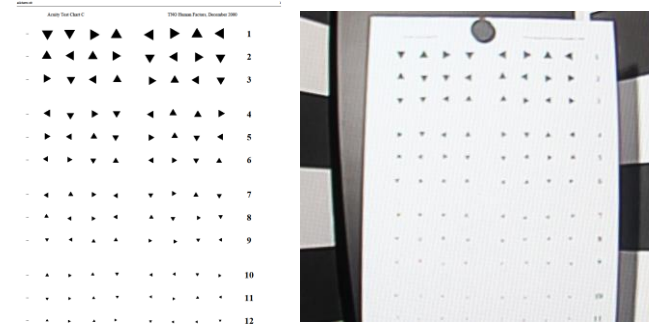
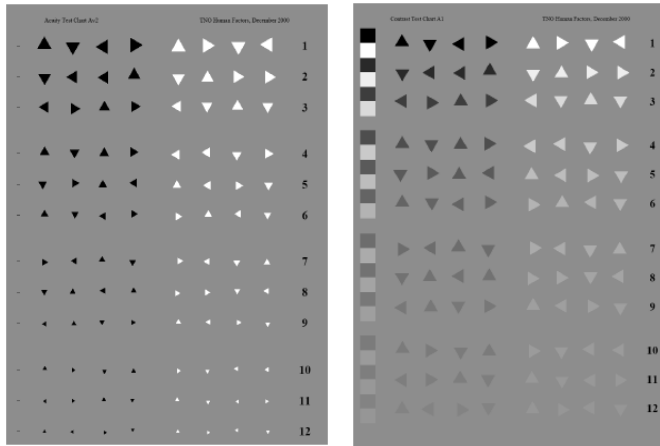

UN ECE-46 test chart for vehicle vision systems



High Quality calibrated VIS/NIR test charts for in/outside use

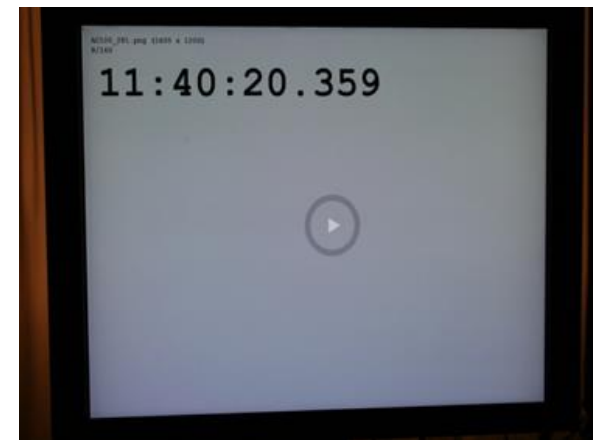

Computer-controlled systems

Test method and equipment

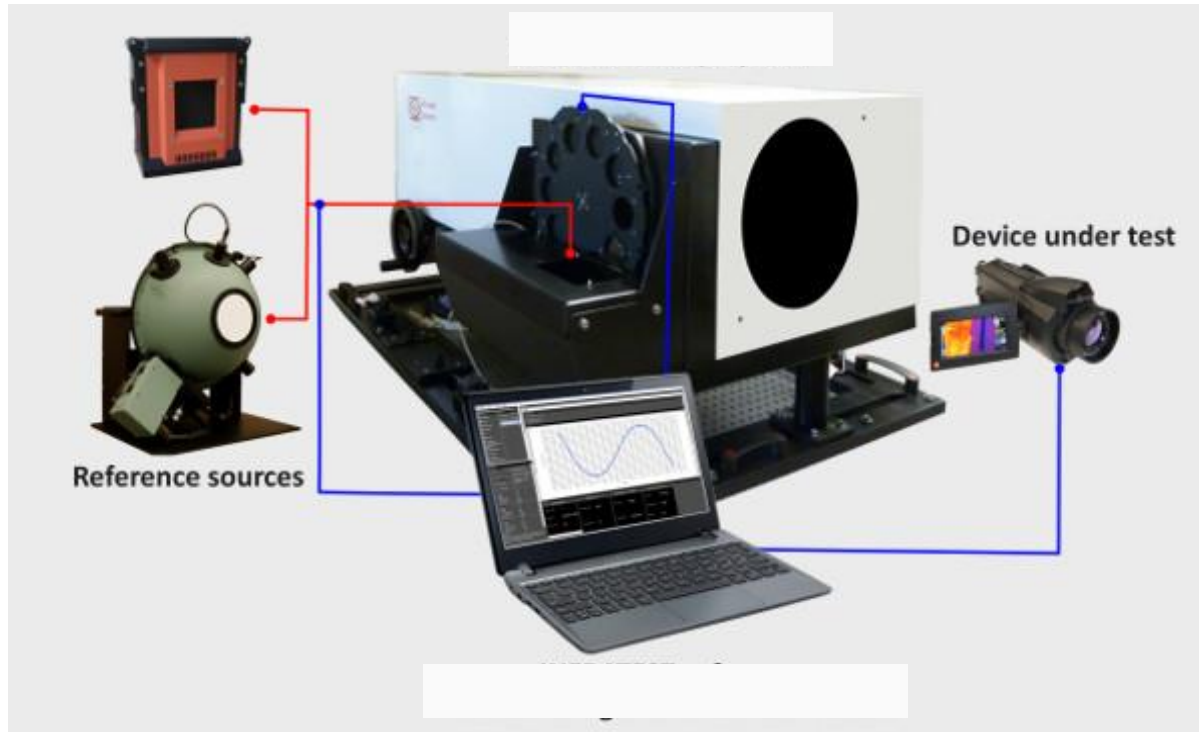

Commercial collimated IR test bench with TOD test



TNOs TCAT for in/outside use

Analytical TOD model

- Analytical TOD model: for quick estimates
- Based on four limiting components: optical blur, sampling, noise and human eye
- Total TOD is Pythagorean sum of component TODs

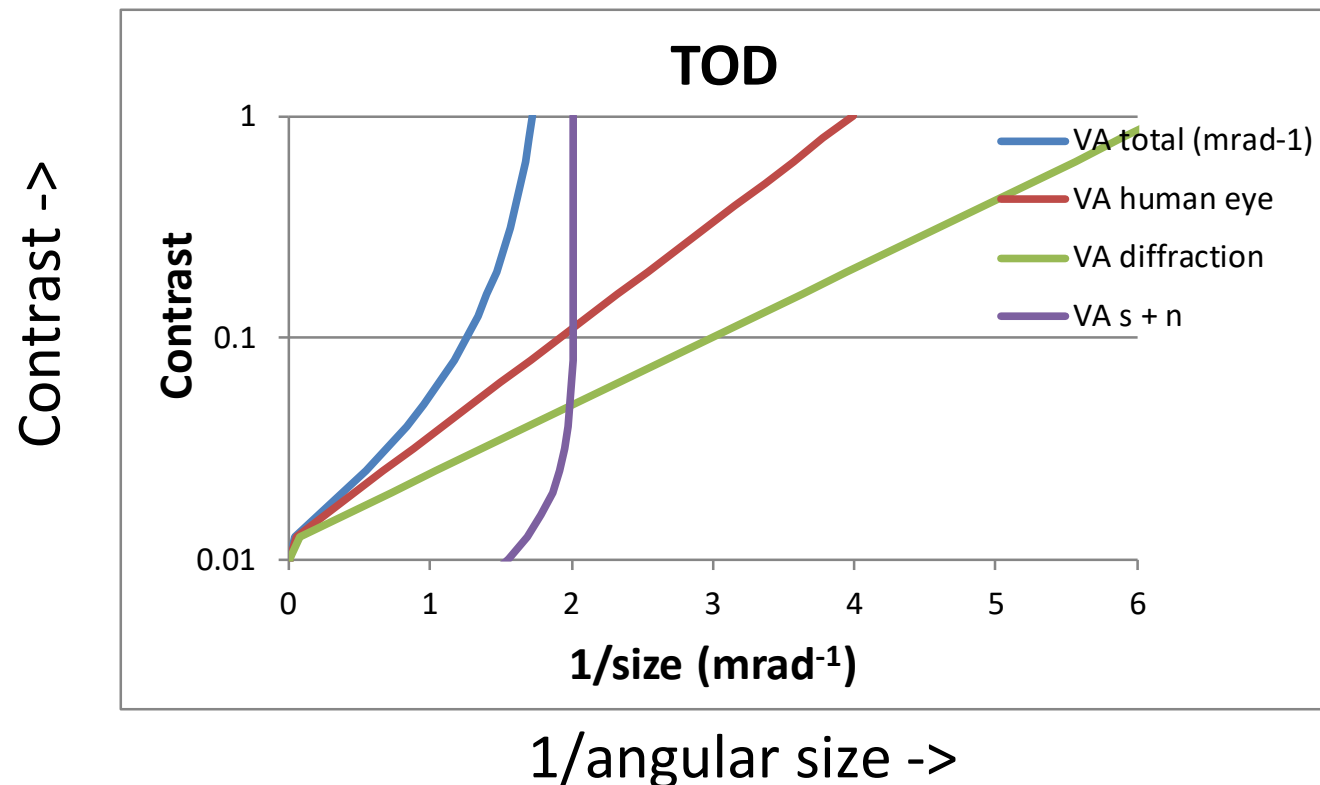

DRI range TOD model

- From the TOD acquisition ranges for target sets, e.g. tactical vehicles or humans, can be predicted:

Target	Task	Corresponding task from Table 7 or Table 8	Thermal Contrast	Characteristic dimension (m)	N ₅₀	M ₇₅
Tactical vehicles	I	12 tracked vehicles, I	4K	3.1	-	8.9
Tactical vehicles	R	Military vehicles, R	4K	3.1	-	6.2
Tactical vehicles	D	Vehicles (moderate clutter), D	4K	3.1	-	1.4
Human	I	Two-handheld objects I, all aspects	2K	0.25	-	8.6
Human	R	Human activities, I, front aspects	3K	0.75	-	5.8
Human	D	Humans, D, moderate clutter	3K	0.75	-	1.4
NATO target	I	NATO target, I	2K	2.3	6	14
NATO target	R	NATO target, R	2K	2.3	3	7
NATO target	D	NATO target, D	2K	2.3	1	2.3

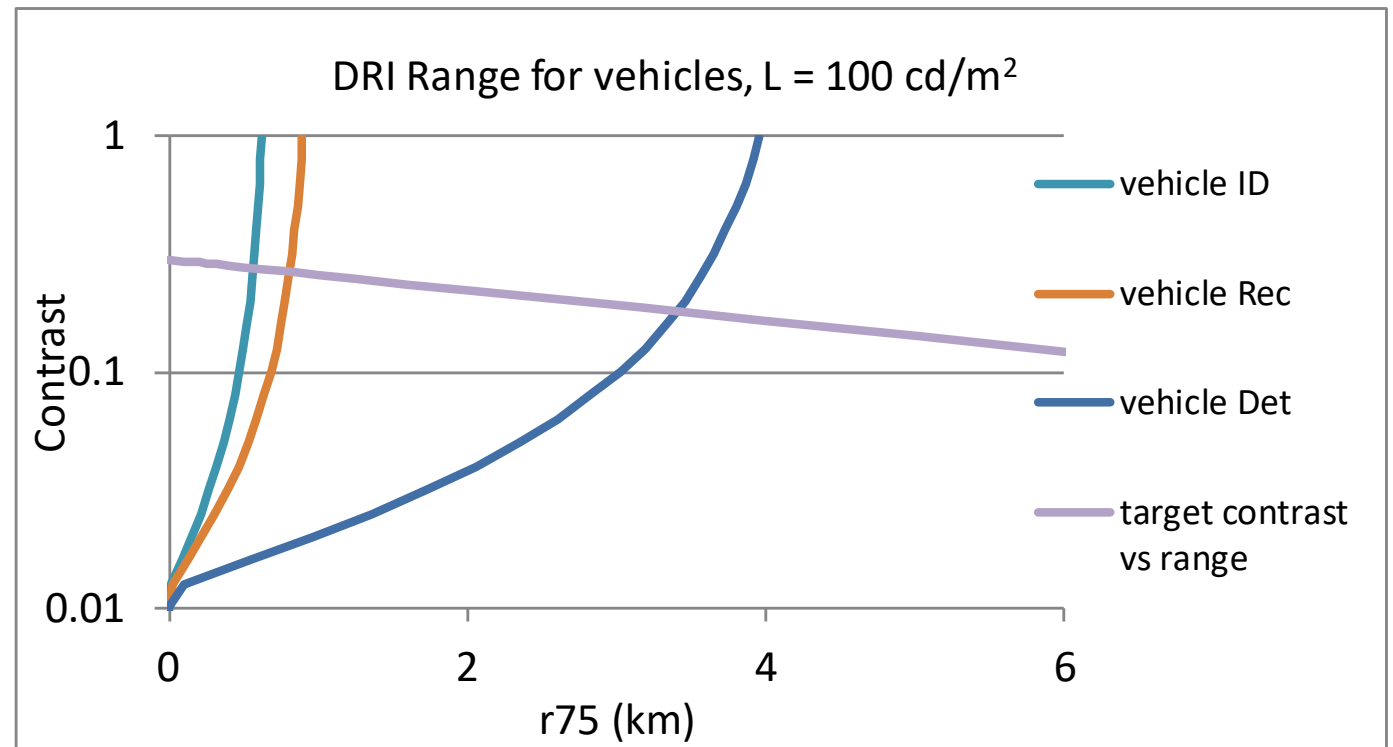

Modelling the Imaging chain: why?

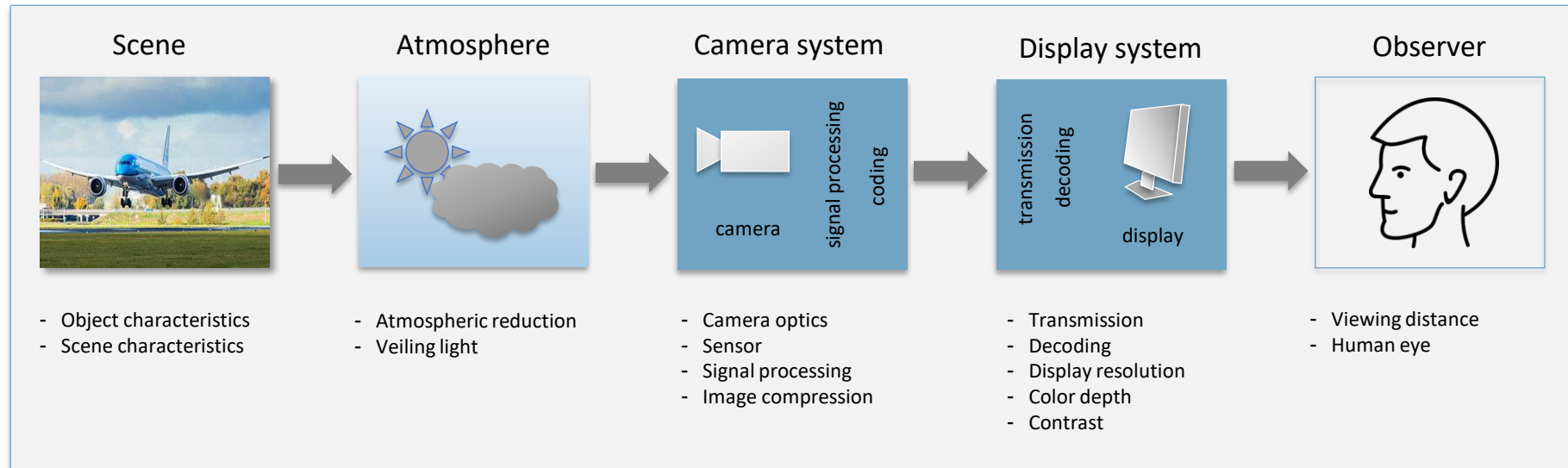

- Performance in terms of DRI depends on a large number of factors and non-linear effects
- Assuming a linear systems approach can be very inaccurate, especially for state-of-the-art imaging systems
- Simulation results can be used in the design phase to predict performance against SWAP-C before the system is built
- Simulation results can be used to illustrate potential customers the images they may expect

Modelling the Imaging chain: How?

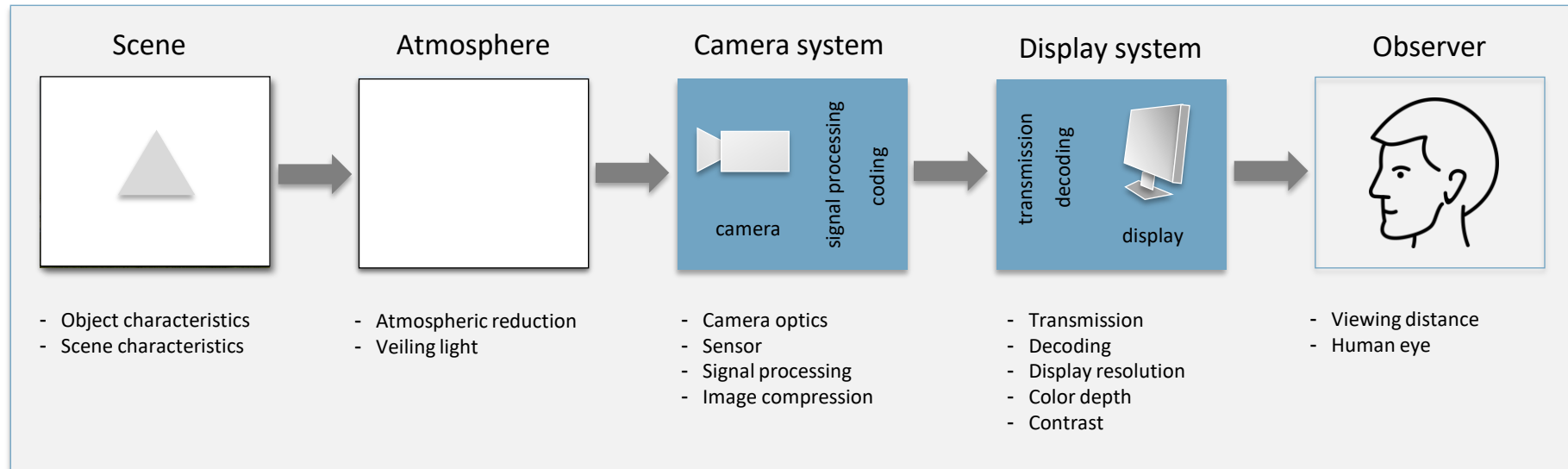

- TOD method very-well suited for image-based modelling:
 - test, camera system, eye
- TNO image-based models over the years:
 - De Lange et al. (2000, 2001); Hogervorst et al., (2003); Bijl et al., (2008); Kessler et al. (2017) (ECOMOS); Bijl & Hogervorst (2019) (EXIST)
- Current status:
 - static chain model, classical static Human Visual System (HVS) model based on correlation and human eye resolution and contrast limitations

Current operational models

- EDA ECOMOS (European Target Acquisition software Model), combination of
 - TRM4 (German classical Target Acquisition model with great user interface),
 - MATISSE (French atmosphere model) and
 - TOD model (Netherlands analytical and image-based simulation model + HVS + DRI range model)
- TOD analytical and HVS model developed on relatively small dataset:
 - TNOs “Fanning set”: 24 sensors, 4 optical blur to detector size ratios; 3 noise levels, 2 up-sampling types
 - Validated against several historical camera tests
- ISET-based visual camera model (developed in EXIST)
 - static chain simulation for RGB cameras to dynamic
 - Validation on a limited set of camera-optics combinations
 - No HVS model implemented yet

ISET simulation of an RGB imaging system

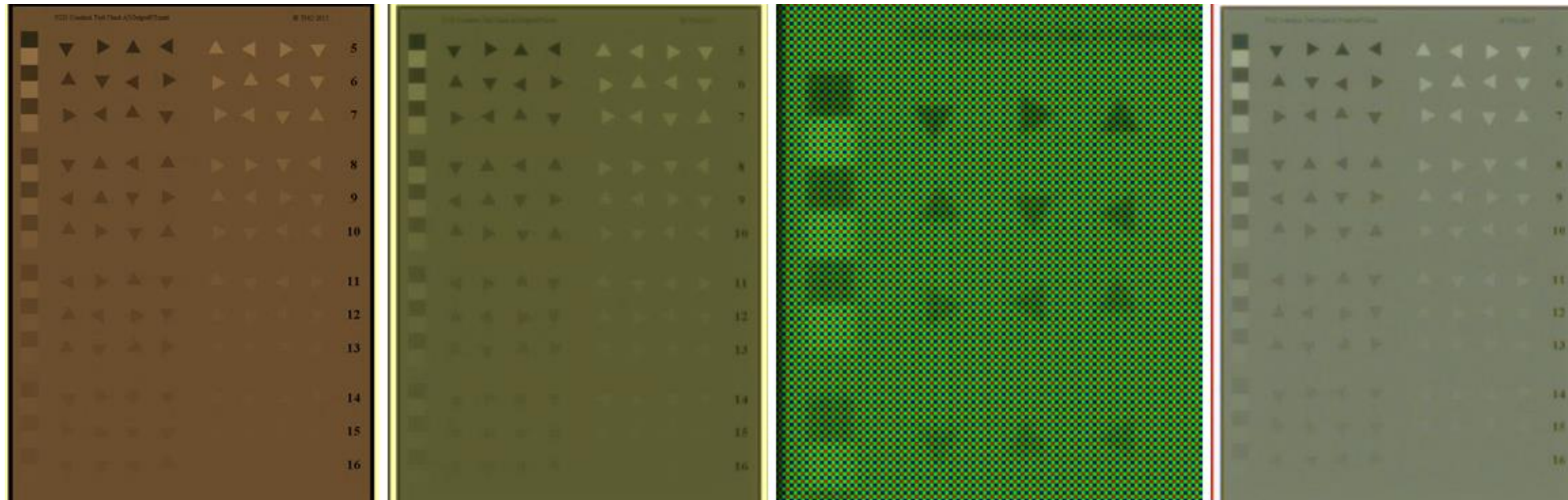

Input: Test chart
illuminated by
illuminant A

Optics

Sampling + Bayer

Reconstruction +
grey world
assumption

Current R&D goals within EU PENTA MANTIS

- Build a large database of TOD perception data for a range of simulated sensor systems, including advanced signal processing, compression, with target motion
 - this is a major extension of TNOs “Fanning set”
- Based on this perception dataset, extend the static classical HVS model to
 - a dynamic classical HVS model
 - a dynamic AI-based HVS model
- Extend the static chain simulation for RGB cameras to dynamic
 - MANTIS Year 2 demonstrator
- Complete the chain with the TOD test and the HVS model
 - MANTIS Year 3 demonstrator
- Validate the model predictions against real camera performance

Final goal: separate camera model + TRAPPIST

- TRAPPIST: TOD-based Range Performance Prediction for Imaging Systems

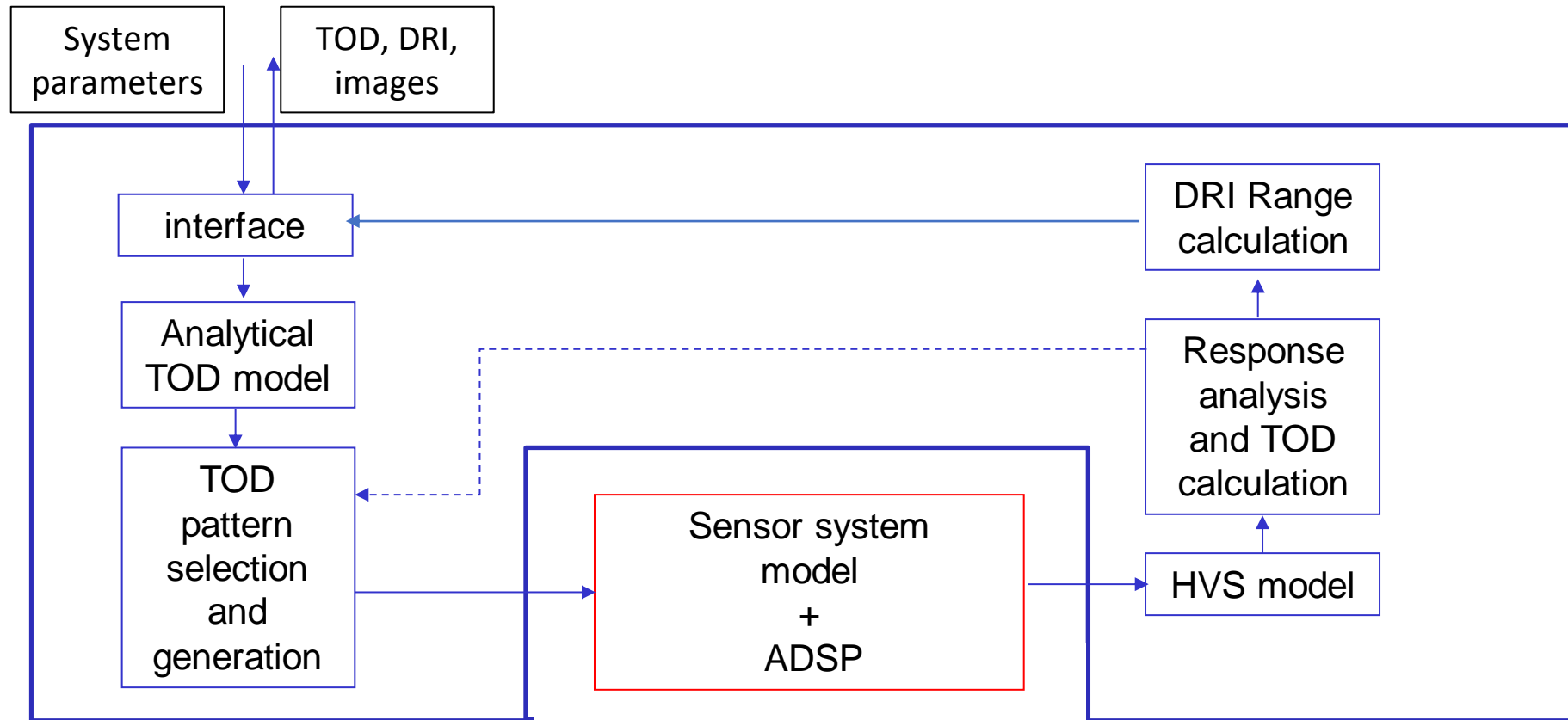

Additional goal: support the selection of suitable camera optics

- Thermal imager: Ideas LWIR core microbolometer
 - Resolution = 640 x 480, spectral range = 8-14 μm , pixel pitch = 12 μm , frame rate = 30Hz, NETD: typical
- Use case: Situational Awareness¹.
 - DRI requirements: Detection of humans @ 90 m, Recognition of human (i.e. human activities) @ 40 m (75% correct level)
- Anticipated solution: three thermal cameras to cover 180 degrees, see picture
 - With the chosen thermal imager, this requires a lens focal length of about 6 mm
- A potentially suitable lens was found on the market
 - Umicore 6.2 mm with F/1 optics



1) Situational Awareness (SA) use case, in the classical definition: being aware of what is happening around you in terms of where you are, where you are supposed to be, and whether anyone or anything around you is a threat to your health and safety. Our definition of situational awareness is where a number of camera's cover a 360-degree field of view and provide a constant real time image on the surroundings for all users of a mobile platform.

Additional goal: support the selection of suitable camera optics

- Question:
 - Does the 3-camera solution provide sufficient DRI performance?
- First impression with the 6.2 mm lens
 - HFOV = 63.6 degrees.
 - Just above the required angle
 - Pixel angular subtense: IFOV = 1.94 mrad
 - 1 pixel subtends 0.2 m at 100 m. This should be sufficient for Detection of humans
 - Lens blur
 - On-axis MTF close to diffraction limit
 - Off-axis MTF at 68 degrees full field about 0.8 times diffraction limit
 - Is the system resolution limited by pixel size or optical blur?
 - $F\lambda/d$ is a measure of blur to sampling ratio. $F = f/D$, λ = wavelength, d = detector size
 - $F\lambda/d = 1.0 * 11 \mu / 12 \mu \approx 0.92 \Rightarrow$ detector size is dominant

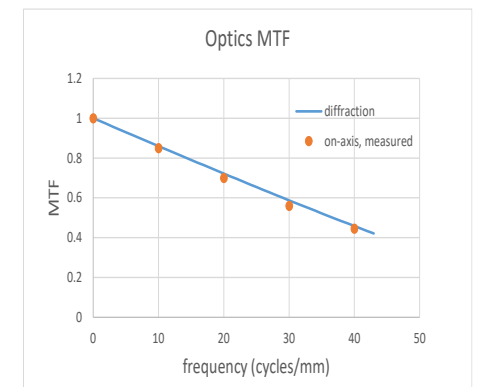
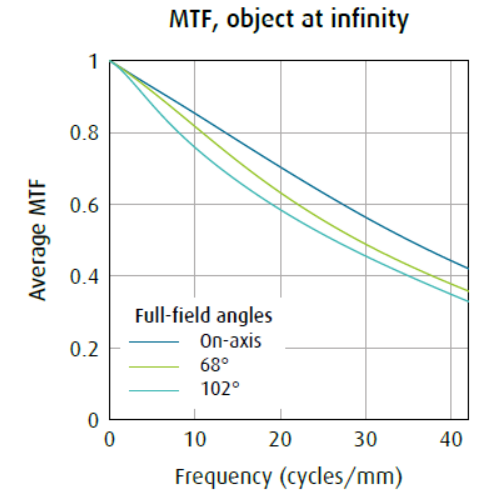

Additional goal: support the selection of suitable camera optics

- TOD calculations
 - No complex signal processing or image motion is used:
 - the analytical TOD model can be used
 - Results: see plot
 - Clearly sampling and noise limited
 - VA cut-off = $0.31 \text{ mrad}^{-1} \approx 1/5^{\text{th}}$ of human Visual Acuity
- Range calculations using the DRI range model and Table of slide 11
 - Human D range = 166 m @75%, sufficient
 - Human R range = 40 m @ 75%, just sufficient
- Conclusion
 - Ideas LWIR core- Umicore 6.2 mm f/1 optics combination meets the range performance requirements
 - An acceptance test on the real camera + optics system can verify whether the predicted TOD performance is really met

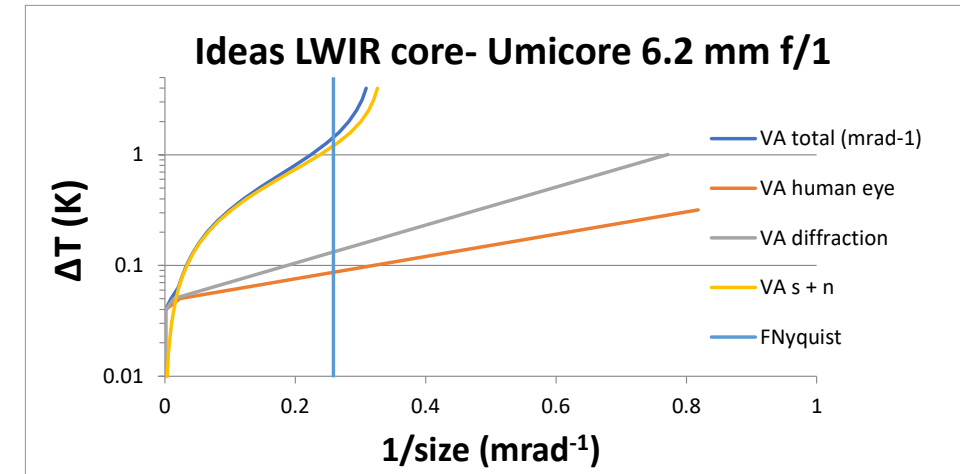

target & task	range (m)
tactical vehicle I	108
tactical vehicle R	155
tactical vehicle D	684
Human I	9
Human R	40
Human D	166

Summary

- Camera system operational performance tests and models have been developed to support:
 - Procurement processes and acceptance testing of advanced imaging systems
 - Complex camera system design
- The current focus in MANTIS Vision is to provide a dynamic image-based simulation of camera systems with (black-box) advanced signal processing, including a performance test, a validated Human Visual System model, and a DRI range model
- Simulation results can be used in the system design phase to
 - predict performance against SWAP-C before a camera system is built
 - predict whether a camera system will meet the requirements
 - illustrate potential customers the images they may expect

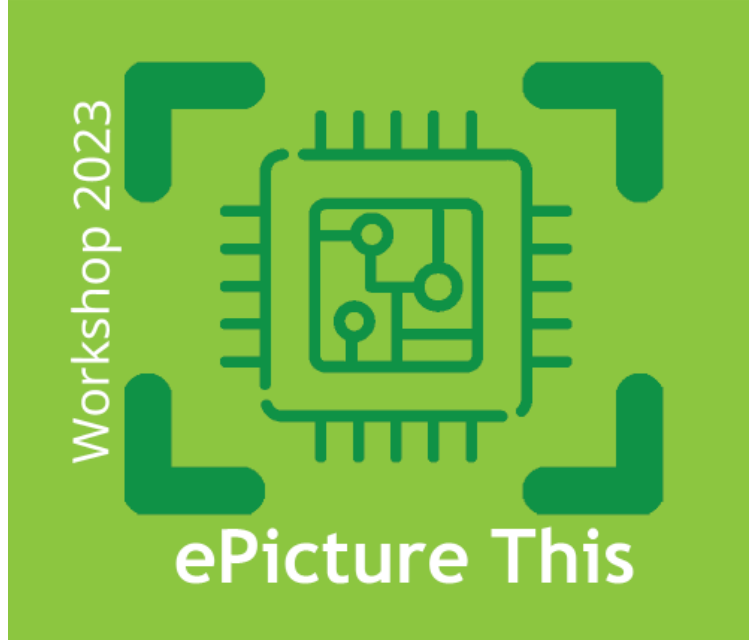

an initiative by PENTA label projects
MANTIS and IMAGINATION with AENEAS support

THANK YOU

